

# GEOMETRY

KUEEN-K

TRIATHLON

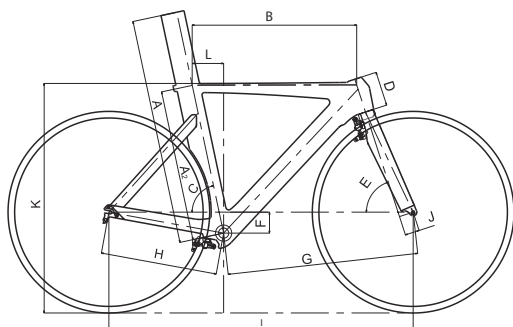

## LEGEND

A	Seat tube total length	H	Chain stay
A <sup>2</sup>	Seat tube joint	I	Wheel base
B	Top tube length	J	Fork rake
C	Seat tube angle	K	Standover height
D	Head tube	L	Standover height offset
E	Head tube angle	P	Frame weight (gr)
F	BB drop	O	Fork weight (gr)
G	BB to front wheel		

## TECHNICAL FEATURES

			SIZE	XS	S	M	L	XL
			A	685	710	735	755	770
Geometria	Geometry	Triathlon/TT	A <sup>2</sup>	435	460	485	505	520
Costruzione	Construction	Mnocoque	B	490	515	530	550	570
Taglie	Sizes	5	C	79°	78,5°	78,5°	78°	78°
Fibra	Weave	3K	D	95	95	105	115	135
Reggisella	Seatpost	AERO Integrated	E	71,5°	72°	72°	72°	72°
Sterzo	Headset	1-1/8" • 1-1/4"	F	72	70	70	70	70
Forcellino	Rear Hanger	Interchangeable	G	586	604	620	637	659
Attacco Der	f.d clamp	Integrated	H	390	390	390	390	390
			I	965	983	1000	1017	1039
Destinazione	Destination	Tri/TT/Professional	J	48	48	48	48	48
Comfort	Comfort	★★★★	K	705	727	749	767	783
Resa dinamica	Dynamic Efficiency	★★★★★	L	91	95	98	105	109
Rigidità/Peso	Rigidity to weight	★★★★★	P*	1100	1130	1160	1180	1200
			O*	390	390	390	390	390

\* TOLERANCES: FRAME ±30 gr without brakes - FORK ±15gr