

GEOMETRY

ROAD

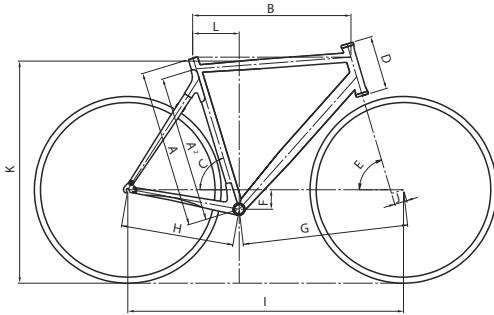

LEGENDA

A	Seat tube total length	E	Head tube angle	J	Fork rake
A ²	Seat tube joint	F	BB drop	K	Standover height
B	Top tube length	G	BB to front wheel	L	Standover height offset
C	Seat tube angle	H	Chain stay	P	Weight
D	Head tube	I	Wheel base		

KEBEL						
SIZE	XS	S	M	L	XL	XXL
A	480	500	530	550	580	610
A ²	422	450	480	500	530	565
B	505	525	540	560	575	590
C	74.5°	73.5°	73.5°	73°	72.5°	72.5°
D	120	125	145	160	180	195
E	72°	72°	72.5°	72.5°	73°	73°
F	70	68	68	68	66	66
G	555,6	567,2	578,5	578,5	599,9	640
H	402	402	402	402	402	402
I	951,5	963,5	974,7	974,7	995,6	1011
J	48	48	48	48	48	48
K	724	740	767	784	811	833
L	128	142	151	161	174	183
P	1110	1120	1130	1160	1190	1230

KEBEL

Geometria	Geometry	Slooping 5 cm	Slooping 5 cm
Costruzione	Structure	Monoscocca	Monocoque
Taglie	Sizes	6	6
Fibra	Weave	12K	12K
Reggisella Ø	Seatpost Ø	AERO	AERO
Sterzo	Headset	1-1/8" • 1-1/4"	1-1/8" • 1-1/4"
Peso	Weight	da 1100 gr	from 1100 gr
Forcellino	Rear hanger	Intercambiabile	Interchangeable
Attacco Der	f.d. clamp	Alluminio integrato	Integrated alu
Destinazione	Destination	Profes./Amatoriale	Prof./Amateur
Comfort	Comfort	★★★★★	
Resa dinamica	Dynamic efficiency	★★★★★	
Rigidità/Peso	Rigidity to weight	★★★★★	