

GEOMETRY

TRIATHLON

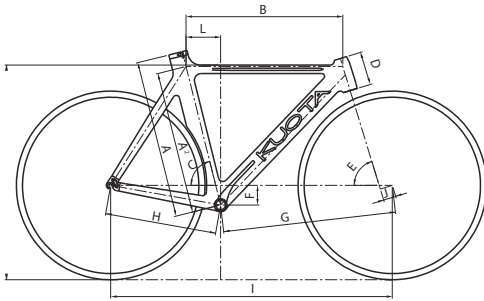

LEGENDA

A	Seat tube total length	E	Head tube angle	J	Fork rake
A ²	Seat tube joint	F	BB drop	K	Standover height
B	Top tube length	G	BB to front wheel	L	Standover height offset
C	Seat tube angle	H	Chain stay	P	Weight
D	Head tube	I	Wheel base		

KALIBUR				
SIZE	S 48-52	M 52-55	L 55-58	XL >58
A	515	545	565	585
A ²	460	490	510	530
B	520	540	560	575
C	76°	76°	76°	76°
D	95	105	120	140
E	72°	72°	73°	73°
F	72	72	70	68
G	586	604	618	634
H	399	399	399	399
I	974	992	1006	1023
J	45	45	45	45
K	721,4	745	767	789
L	118,7	118,5	123	129,4
P	1080	1120	1160	1190

KALIBUR

Geometria	Geometry	Quadro	Square
Costruzione	Structure	Monoscocca	Monocoque
Taglie	Sizes	4	4
Fibra	Weave	3K	3K
Reggisella Ø	Seatpost Ø	AERO	AERO
Sterzo	Headset	1-1/8" • 1-1/4"	1-1/8" • 1-1/4"
Peso	Weight	da 1080 gr	from 1080 gr
Forcellino	Rear hanger	Intercambiabile	Interchangeable
Attacco Der	f.d. clamp	Inox integrato	Integrated inox
Destinazione	Destination	Strada professionale	Road professional
Comfort	Comfort	★★★★★	
Resa dinamica	Dynamic efficiency	★★★★★	
Rigidità/Peso	Rigidity to weight	★★★★★	